

# ***MC-780Pix CCD Camera User's Guide***

*SOCU006*

*July 1998*



Printed on Recycled Paper

## IMPORTANT NOTICE

Texas Instruments and its subsidiaries (TI) reserve the right to make changes to their products or to discontinue any product or service without notice, and advise customers to obtain the latest version of relevant information to verify, before placing orders, that information being relied on is current and complete. All products are sold subject to the terms and conditions of sale supplied at the time of order acknowledgement, including those pertaining to warranty, patent infringement, and limitation of liability.

TI warrants performance of its semiconductor products to the specifications applicable at the time of sale in accordance with TI's standard warranty. Testing and other quality control techniques are utilized to the extent TI deems necessary to support this warranty. Specific testing of all parameters of each device is not necessarily performed, except those mandated by government requirements.

CERTAIN APPLICATIONS USING SEMICONDUCTOR PRODUCTS MAY INVOLVE POTENTIAL RISKS OF DEATH, PERSONAL INJURY, OR SEVERE PROPERTY OR ENVIRONMENTAL DAMAGE ("CRITICAL APPLICATIONS"). TI SEMICONDUCTOR PRODUCTS ARE NOT DESIGNED, AUTHORIZED, OR WARRANTED TO BE SUITABLE FOR USE IN LIFE-SUPPORT DEVICES OR SYSTEMS OR OTHER CRITICAL APPLICATIONS. INCLUSION OF TI PRODUCTS IN SUCH APPLICATIONS IS UNDERSTOOD TO BE FULLY AT THE CUSTOMER'S RISK.

In order to minimize risks associated with the customer's applications, adequate design and operating safeguards must be provided by the customer to minimize inherent or procedural hazards.

TI assumes no liability for applications assistance or customer product design. TI does not warrant or represent that any license, either express or implied, is granted under any patent right, copyright, mask work right, or other intellectual property right of TI covering or relating to any combination, machine, or process in which such semiconductor products or services might be or are used. TI's publication of information regarding any third party's products or services does not constitute TI's approval, warranty or endorsement thereof.

# Read This First

---

---

---

---

### ***About This Manual***

This User's Guide describes the characteristics and operation of the MC-780PIA and MC-780PIH CCD Video Camera Modules.

### ***How to Use This Manual***

Use this manual for technical data, operating characteristics, and general familiarization with the products before, during, and after installation.

### ***Information About Cautions and Warnings***

This book may contain cautions and warnings.

**This is an example of a caution statement.**

**A caution statement describes a situation that could potentially damage your software or equipment.**

**This is an example of a warning statement.**

**A warning statement describes a situation that could potentially cause harm to you.**

The information in a caution or a warning is provided for your protection. Please read each caution and warning carefully.

---

## If You Need Assistance . . .

<b>If you want . . .</b>	<b>Contact Texas Instruments at . . .</b>
Visit TI online	World Wide Web: <a href="http://www.ti.com">http://www.ti.com</a>
Receive general information or assistance	World Wide Web: <a href="http://www.ti.com/sc/docs/pic/home.htm">http://www.ti.com/sc/docs/pic/home.htm</a> North America, South America: (214) 644-5580 Europe, Middle East, Africa Dutch: 33-1-3070-1166 English: 33-1-3070-1165 French: 33-1-3070-1164 Italian: 33-1-3070-1167 German: 33-1-3070-1168 Japan (Japanese or English) Domestic toll-free: 0120-81-0026 International: 81-3-3457-0972 or 81-3-3457-0976 Korea (Korean or English): 82-2-551-2804 Taiwan (Chinese or English): 886-2-3771450
Ask questions about Digital Signal Processor (DSP) product operation or report suspected problems	(713) 274-2320 Fax: (713) 274-2324 Fax Europe: +33-1-3070-1032 Email: <a href="mailto:dsph@ti.com">dsph@ti.com</a> World Wide Web: <a href="http://www.ti.com/dsps">http://www.ti.com/dsps</a> BBS North America: (713) 274-2323 8-N-1 BBS Europe: +44-2-3422-3248 320 BBS Online: <a href="ftp://ti.com/mirrors/tms320bbs">ftp://ti.com/mirrors/tms320bbs</a> (192.94.94.53)
Ask questions about micro-controller product operation or report suspected problems	(713) 274-2370 Fax: (713) 274-4203 Email: <a href="mailto:*H370@msg.ti.com">*H370@msg.ti.com</a> World Wide Web: <a href="http://www.ti.com/sc/micro">http://www.ti.com/sc/micro</a> BBS: (713) 274-3700 8-N-1
Request tool updates	Software: (214) 638-0333 Software fax: (214) 638-7742 Hardware: (713) 274-2285
Order Texas Instruments documentation (see Note 1)	Literature Response Center: (800) 477-8924
Make suggestions about or report errors in documentation (see Note 2)	Email: <a href="mailto:comments@books.sc.ti.com">comments@books.sc.ti.com</a> Mail: Texas Instruments Incorporated Technical Publications Manager, MS 702 P.O. Box 1443 Houston, Texas 77251-1443

- Notes:**
- 1) The literature number for the book is required; see the lower-right corner on the back cover.
  - 2) Please mention the full title of the book, the literature number from the lower-right corner of the back cover, and the publication date from the spine or front cover.

# Contents

---

---

---

<b>1</b>	<b>Overview</b>	<b>1-1</b>
1.1	Main Features	1-2
1.1.1	High Image Quality	1-2
1.1.2	Mode Settings	1-2
1.1.3	External Sync	1-2
1.1.4	Output of Internal Synchronizing Signals	1-2
1.1.5	Electronic Shutter	1-2
1.2	Other Features	1-3
<b>2</b>	<b>Nomenclature and Use of Each Component</b>	<b>2-1</b>
2.1	Mounting System	2-2
2.1.1	Focus Ring	2-2
2.1.2	Mounting Holes A	2-2
2.1.3	Mounting Hole B	2-2
2.1.4	Mounting Holes C	2-2
2.2	Rear Panel Switches and Terminals	2-3
2.2.1	Shutter Speed Control Switch SW1	2-3
2.2.2	External Synchronization Terminal Resistance Switch SW4	2-4
2.2.3	Mode Switches SW3	2-4
2.2.4	Gain Mode Switch SW2	2-5
2.2.5	Gain Variable Volume Control VR1	2-5
2.2.6	DC IN Terminal	2-6
2.2.7	LENS Terminal	2-6
2.2.8	DC IN/SYNC Terminal	2-6
2.3	Internal Switches	2-8
2.3.1	SYNC Signal (HD/VD) Input/Output Switch SW1	2-8
2.3.2	Option Output Switch S1	2-9
2.3.3	Gamma Switch SW1	2-9
2.3.4	AC/DC Output Switch SW4	2-10
2.3.5	Outline Emphasis Circuit ON/OFF Switch SW2	2-10
<b>3</b>	<b>Using the External SYNC Mode</b>	<b>3-1</b>
3.1	External Sync With Interlace	3-2
3.1.1	External Sync Signal Input Conditions	3-2
3.2	External Sync With No Interlace	3-3
3.2.1	External Sync Signal Input Conditions	3-3
<b>4</b>	<b>Using the Shutter Modes</b>	<b>4-1</b>
4.1	Continuous Shutter	4-2

4.2	Random Shutter (Fixed V Sync) .....	4-3
4.3	Random Shutter (V Sync Reset) .....	4-4
4.4	VI Mode Shutter .....	4-5
4.5	Precautionary Items .....	4-6
<b>5</b>	<b>Initial Settings</b> .....	<b>5-1</b>
5.1	Modes and Initial Switch Settings .....	5-2
<b>6</b>	<b>Precautions for Use</b> .....	<b>6-1</b>
6.1	Precautions for Use .....	6-2
6.1.1	Power Source .....	6-2
6.1.2	Heat Reduction .....	6-2
6.1.3	Locations for Use and Storage .....	6-2
6.2	Maintenance .....	6-3
<b>7</b>	<b>Specifications</b> .....	<b>7-1</b>
7.1	Image System .....	7-2
7.2	Optical Elements and Other Specifications .....	7-3
<b>8</b>	<b>Exterior Dimensions</b> .....	<b>8-1</b>
8.1	Exterior Dimensions .....	8-2
<b>9</b>	<b>Other Issues</b> .....	<b>9-1</b>
9.1	Connectors .....	9-2

# Figures

---

---

2-1	Rear Panel .....	2-3
2-2	External Synchronization Terminal Resistance Switch SW4 .....	2-4
2-3	Gain Mode Switch SW2 .....	2-5
2-4	Gain Variable Volume Control VR1 .....	2-5
2-5	Internal Switches .....	2-8
2-6	SYNC Signal (HD/VD) Input/Output Switch SW1 .....	2-9
2-7	Option Output Switch S1 .....	2-9
2-8	Gamma Switch SW1 .....	2-9
2-9	AC/DC Output Switch SW4 .....	2-10
2-10	Outline Emphasis Circuit ON/OFF Switch SW2 .....	2-10
3-1	External Sync Timing .....	3-2
3-2	External Sync With No Interlace .....	3-3
4-1	Continuous Shutter Speed-Control Timing .....	4-2
4-2	Random Shutter Control Timing (Fixed V Sync) .....	4-3
4-3	Random Shutter Control Timing (V Sync Reset) .....	4-4
4-4	VI Mode Shutter Timing .....	4-5
4-5	Exposure and Transfer Period Conflict With Readout Period .....	4-6
8-1	Exterior Dimensions .....	8-3

# Tables

---

---

---

2-1	Shutter Speed Control Switch SW1 .....	2-3
2-2	External Synchronization Terminal Resistance Switch SW4 .....	2-4
2-3	Mode Switches SW3 .....	2-4
2-4	Shutter list .....	2-5
2-5	Gain Mode Switch SW2 .....	2-5
2-6	LENS Terminal .....	2-6
2-7	DC IN/SYNC Terminal .....	2-7
2-8	SYNC Signal (HD/VD) Input/Output Switch SW1 .....	2-8
2-9	Option Output Switch S1 .....	2-9
2-10	Gamma Switch SW1 .....	2-9
2-11	AC/DC Output Switch SW4 .....	2-10
2-12	Outline Emphasis Circuit ON/OFF Switch SW2 .....	2-10
4-1	Line Corresponding to Shutter Speeds .....	4-6
5-1	Modes and Initial Switch Settings .....	5-3
7-1	MC-780PIA Image System Specifications .....	7-2
7-2	MC-780PIH Image System Specifications .....	7-2
7-3	Optical Elements and Other Specifications .....	7-3



# Overview

---

---

---

---

---

This User's Guide describes the operation and characteristics of the MC-780PIA and MC780PIH video cameras. This chapter gives an overview of the cameras and their features. Please read and keep this document as a reference.

<b>Topic</b>	<b>Page</b>
1.1 Main Features .....	1-2
1.6 Other Features .....	1-3

## 1.1 Main Features

The MC-780PIA and MC-780PIH are black-and-white video cameras that use fixed-sensor charge-coupled devices (CCDs). The following paragraphs describe some of the main features of the cameras.

### 1.1.1 High Image Quality

With 380,000 image-sensing elements, the CCDs reproduce very detailed images.

### 1.1.2 Mode Settings

Several modes can be selected depending on the intended use. For example, using external switches for gain, it is possible to select A (auto adjust), F (fixed), or M (manual adjust); using the internal switches for  $\gamma$  [gamma] characteristics, it is possible to select ON (corrected:  $\gamma = 0.45$ ) and OFF (uncorrected:  $\gamma = 1$ ).

### 1.1.3 External Sync

The camera module can be operated with external sync by inputting HD and VD signals. Internal or external sync can be selected with the mode switches.

### 1.1.4 Output of Internal Synchronizing Signals

HD and VD signals can be output by switching their internal switches. Pixel clock signals and shutter monitor signals can also be selected and output.

### 1.1.5 Electronic Shutter

A shutter speed can be selected from 1/500 to 1/8000 second to match sensing conditions. It is possible to select continuous shutter, random shutter, or optional time shutter.

## 1.2 Other Features

- Long life span, high reliability
- Low distortion, high precision image
- High near infrared sensitivity
- Quick starting



# Nomenclature and Use of Each Component

---

---

---

---

This chapter describes the location and use of components, connectors, and controls.

<b>Topic</b>	<b>Page</b>
<b>2-1 Mounting System</b> .....	<b>2-2</b>
<b>2-2 Rear Panel Switches and Terminals</b> .....	<b>2-3</b>
<b>2-3 Internal Switches</b> .....	<b>2-8</b>

## **2.1 Mounting System**

The following paragraphs describe the mounting system for the camera modules.

### **2.1.1 Focus Ring**

C-Mount type lens and optical equipment are installed. If there is difficulty focusing with the lens, fine adjustments can be made by loosening the two screws located on the ring. The lens can also be brought back closer to the CCD by removing the focus ring.

### **2.1.2 Mounting Holes A**

There are four screw holes on the top and bottom for mounting the camera module. The gauge is M2.6 and the depth is 4.5 mm.

### **2.1.3 Mounting Hole B**

There is a screw hole on the bottom for mounting the camera module. The gauge is M4 and the depth is 6 mm.

### **2.1.4 Mounting Holes C**

There are screw holes on the bottom for mounting the camera module to a tripod. The gauge is 1/4UNC and the depth is 6 mm.

**2.2 Rear Panel Switches and Terminals**

This paragraph explains the functions of the rear panel switches and terminals. Figure 2-1 shows their locations.

**Changing Switch Settings**  
 Always disconnect power when changing the switch settings.

CAUTION

Figure 2-1. Rear Panel

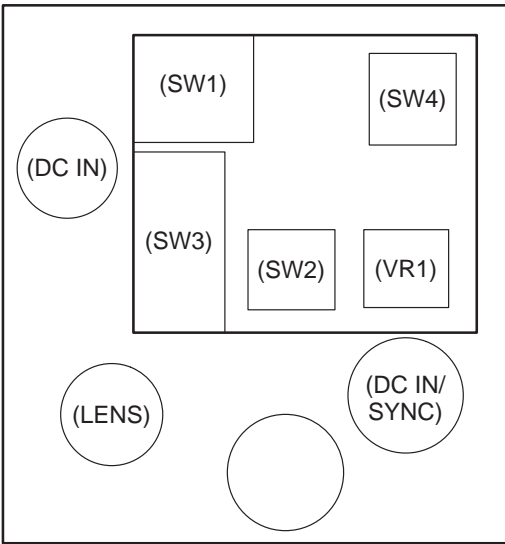

**2.2.1 Shutter Speed Control Switch SW1**

Switch SW1 sets the electronic shutter speed. Table 2-1 shows the shutter speed settings.

Table 2-1. Shutter Speed Control Switch SW1

Setting No.	Shutter Speed	Setting No.	Shutter Speed
0	1/500	5	1/3000
1	1/750	6	1/4000
2	1/1000	7	1/8000
3	1/1500	8	not used
4	1/2000	9	not used

**2.2.2 External Synchronization Terminal Resistance Switch SW4**

Switch SW4 sets the resistance of the external synchronization terminal. Table 2-2 lists the settings.

Table 2–2. External Synchronization Terminal Resistance Switch SW4

Switch Position	Terminal Resistance Value
Left	75 Ω
Center	100 kΩ
Right	150 Ω

Figure 2–2. External Synchronization Terminal Resistance Switch SW4

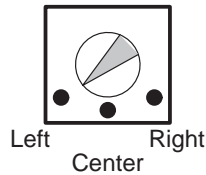

**Note:**

When outputting internal sync signal, set the switch to 100 kΩ.

**2.2.3 Mode Switches SW3**

The SW3 mode switches control the functions listed in Table 2–2 and Table 2–4.

Table 2–3. Mode Switches SW3

Switch No.	Mode	Operation
1	Shutter 1	Refer to list below
2	Shutter 2	Refer to list below
3	External sync	ON for external sync
4	External sync	ON for external sync
5	Interlace/noninterlace	ON for interlace
6	Not used	

Table 2–4. Shutter list

Shutter 1	Shutter 2	Mode
OFF	OFF	Shutter OFF (1/60 sec. exposure)
ON	OFF	Continuous shutter, see Note 1
ON	ON	Continuous shutter, see Note 2
OFF	ON	V.I. (Variable Integration)

**Notes:** 1) V reset not done when external trigger is input.  
 2) V reset done when external trigger is input.

**2.2.4 Gain Mode Switch SW2**

Gain mode switch SW2 controls the gain as shown in Table 2–5 and Figure 2–3.



Table 2–5. Gain Mode Switch SW2

Switch No.	Gain Mode
Left	AGC
Center	Fixed
Right	Variable

Figure 2–3. Gain Mode Switch SW2

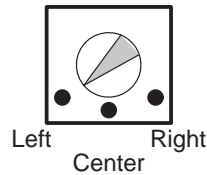

### 2.2.5 Gain Variable Volume Control VR1

When variable gain is selected with gain mode switch SW2 in the right position, gain is increased by turning VR1 counterclockwise as shown in Figure 2–4.

Figure 2–4. Gain Variable Volume Control VR1

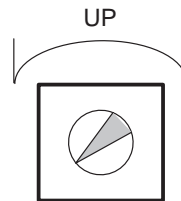

### 2.2.6 DC IN Terminal

Use when the power source is supplied by the AC adaptor: PS-780-12J. When a different type of power source is used, the connector standard must conform to EIAJ, RC-5320A Voltage Classification 4.

### 2.2.7 LENS Terminal

When the auto-iris lens plug is connected, the lens iris can be adjusted automatically. This is also the terminal for inputting the shutter trigger cable connector: HR10A-7P–6P. Table 2–6 lists the terminal pins, signals, and levels.

Table 2–6. LENS Terminal

Pin No.	Input Signal	Signal Level
1	Field index output	Good for HC125
2	Shutter trigger input VI command input	CMOS level
3	Ground	
4	Readout field indicator output	Good for HC125
5	Image signal output (for iris)	
6	DC + 12V output (for lens)	

- The odd fields are low and the even fields are high for the pin 1 field index output.
- The pin 5 image signal is provided for auto-iris use so it cannot be connected to a monitor.
- The dc voltage output from pin 6 is the same as the input voltage.

### 2.2.8 DC IN/SYNC Terminal

This terminal supplies the +12 V power, outputs the image from the camera module, and inputs/outputs sync signals, through cable connector HR10A-10P-12S. Table 2-7 lists the terminal pins, signals, and levels.

Table 2-7. DC IN/SYNC Terminal

Pin No.	Input/Output Signal	Signal Level
1	GND	
2	DC + 12V	
3	Image output (GND)	
4	Image output (signal)	
5	HD input/output	
6	HD input (signal)	For HCT14
	HD output (signal)	For HC125
7	VD input (signal)	For HCT14
	VD output (signal)	For HC125
8	Optional output (GND)	
9	Optional output (signal)	For HC126
10	GND	
11	DC + 12V	
12	VD input/output (GND)	

- The optional outputs on pins 8 and 9 select shutter monitor output or pixel clock output.

### 2.3 Internal Switches

Remove the camera cover to set the internal switches. Viewing the camera from the front, the switches are located on boards in the center and the left. The center board is called the clock board, and the left board is called the process board. Figure 2–5 shows the switch locations.

Figure 2–5. Internal Switches

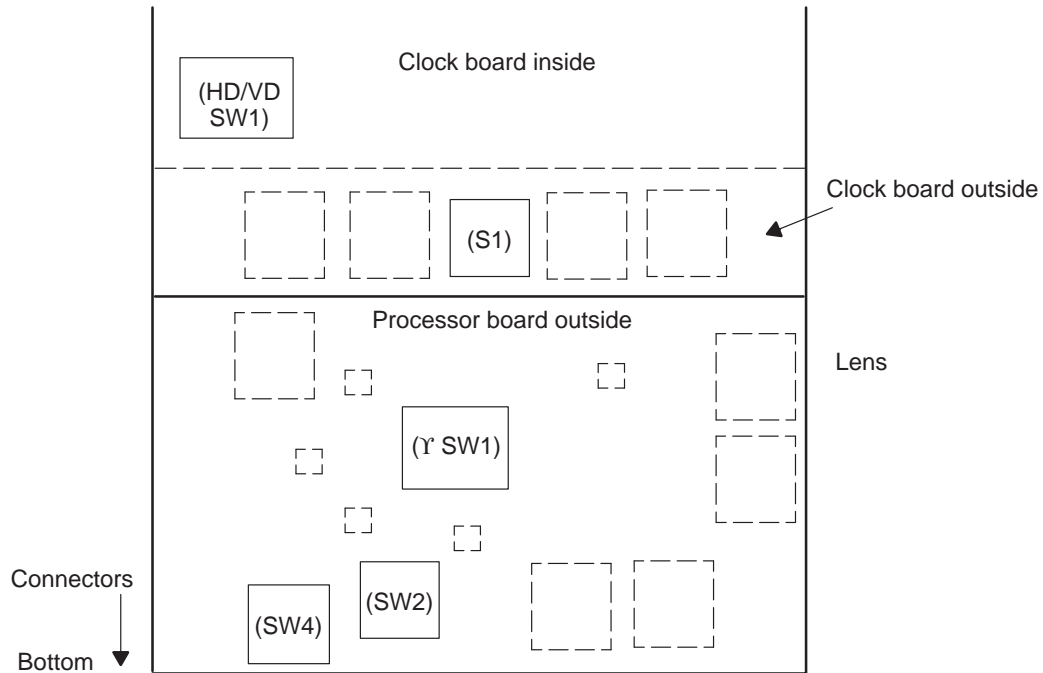

#### 2.3.1 SYNC Signal (HD/VD) Input/Output Switch SW1

Switch SW1 selects between internal sync output and external sync input. Table 2–8 lists the switch positions and functions, and Figure 2–6 shows the switch.

Table 2–8. SYNC Signal (HD/VD) Input/Output Switch SW1

Switch Position	Input/Output Mode
Upper	External sync signal input
Center	Not used
Lower	Internal sync signal output

Figure 2–6. SYNC Signal (HD/VD) Input/Output Switch SW1

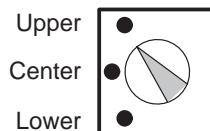

#### 2.3.2 Option Output Switch S1

Switch S1 switches the option output as listed in Table 2–9 and shown in Figure 2–7.

Table 2–9. Option Output Switch S1

Switch Position	Output Signal
Upper	Shutter monitor output
Lower	Pixel clock output

Figure 2–7. Option Output Switch S1

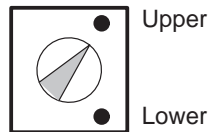

### 2.3.3 Gamma Switch SW1

Gamma switch SW1 changes the gamma characteristics as listed in Table 2–10 and shown in Figure 2–8.

Table 2–10. Gamma Switch SW1

Switch Position	Gamma Characteristics
Upper	$\gamma$ [gamma] = 1 (OFF)
Center	Not used
Lower	$\gamma$ [gamma] = 0.45 (ON)

Figure 2–8. Gamma Switch SW1

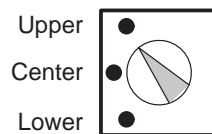

### 2.3.4 AC/DC Output Switch SW4

Switch SW4 switches the output between ac and dc as listed in Table 2–11 and shown in Figure 2–9.

Table 2–11. AC/DC Output Switch SW4

Switch Position	Output Conversion
Upper0	DC output
Center	Not used
Lower	AC combined output

Figure 2–9. AC/DC Output Switch SW4

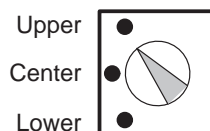

### 2.3.5 Outline Emphasis Circuit ON/OFF Switch SW2

Switch SW2 controls the outline emphasis circuit on the MC-780PIH. **Do not move this switch on the MC-780PIA.** The outline emphasis circuit makes the image easier to see by emphasizing the image outline when the camera is used for surveillance. Table 2–12 lists the switch positions and functions, and Figure 2–10 shows the switch.

Table 2–12. Outline Emphasis Circuit ON/OFF Switch SW2

Switch Position	Operation
Upper	Outline emphasis ON
Center	Not used
Lower	Outline emphasis OFF

Figure 2–10. Outline Emphasis Circuit ON/OFF Switch SW2

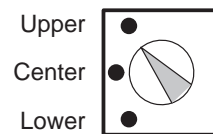

**Note:** This function is only for MC-780PIH.



# Using the External SYNC Mode

---

---

---

---

The camera can be synchronized externally by inputting an external sync signal. When using external sync, set the clock board's sync signal input/output switch (SW1) to the external sync signal in (upper switch position) and switches 3 and 4 to the mode switch (SW3), located on the rear panel, to ON.

<b>Topic</b>	<b>Page</b>
<b>3.1 External Sync With Interface .....</b>	<b>3-2</b>
<b>3.2 External Sync With No Interface .....</b>	<b>3-3</b>

### 3.1 External Sync With Interlace

On the rear panel, set switch 5 of mode switch SW3 to ON.

#### 3.1.1 External Sync Signal Input Conditions

- HD signals:  $15.734 \text{ kHz} \pm 1\%$  ( $63.5 \mu\text{s} \pm 1\%$ )
- VD signals:  $262.5 \text{ H}$
- Phase

In Figure 3–1, when the last VD transition is between  $47.42 \mu\text{s}$  ahead and  $16.13 \mu\text{s}$  behind relative to the last HD transition, it becomes the ODD field.

When the last VD transition is between  $16.13 \mu\text{s}$  ahead and  $47.42 \mu\text{s}$  behind relative to a  $1/2 \text{ H}$  point from the last HD transition, it becomes the EVEN field.

Figure 3–1. External Sync Timing

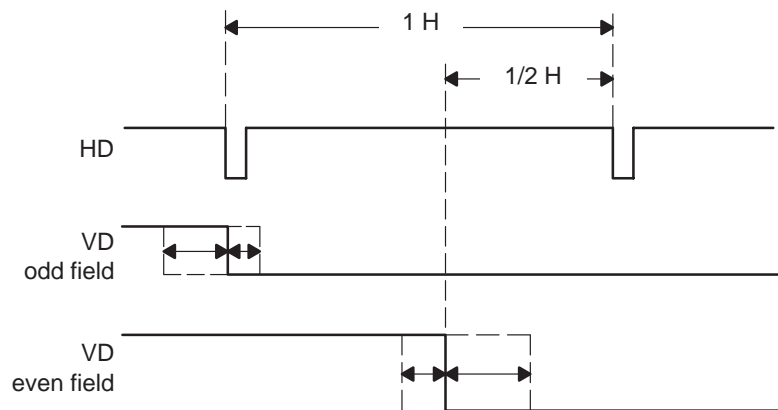



## 3.2 External Sync With No Interlace

On the rear panel, set switch 5 of mode switch SW3 to OFF.

### 3.2.1 External Sync Signal Input Conditions

- HD signals:  $15.734 \text{ kHz} \pm 1\%$  ( $63.5 \mu\text{s} \pm 1\%$ )
- VD signals: 244 ~ 1021 H, (see Notes 1, and 2)
- Phase

Figure 3-2. External Sync With No Interlace

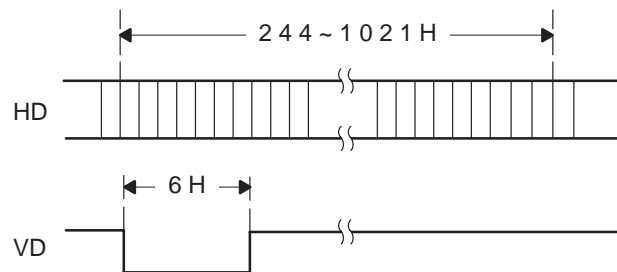

- Notes:**
- 1) The sync becomes internal sync if the VD does not come above 1022H.
  - 2) VD does not receive 0~243H



# Using the Shutter Modes

---

---

---

---

This chapter describes the various shutter modes and how to use them.

<b>Topic</b>	<b>Page</b>
4.1 Continuous Shutter .....	4-2
4.2 Random Shutter (Fixed V Sync) .....	4-3
4.3 Random Shutter (V Sync Reset) .....	4-4
4.4 VI Mode Shutter .....	4-5
4.5 Precautionary Items .....	4-6

## 4.1 Continuous Shutter

On the rear panel mode switch SW3, set switch 1 to ON and switch 2 to OFF. Use the shutter speed control switch SW1 to set the shutter speed. Figure 4–1 shows the continuous shutter speed control timing.

Figure 4–1. Continuous Shutter Speed-Control Timing

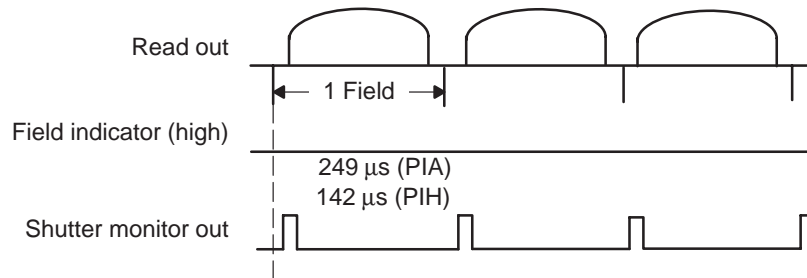

## 4.2 Random Shutter (Fixed V Sync)

On the rear panel mode switch SW3, set switch 1 to ON and switch 2 to OFF. Use the shutter speed control switch SW1 to set the shutter speed.

The random shutter operates only when the shutter command has been added, so continuous shutter is the normal operating mode.

Figure 4–2 shows the random shutter speed control timing with fixed V sync.

Figure 4–2. Random Shutter Control Timing (Fixed V Sync)

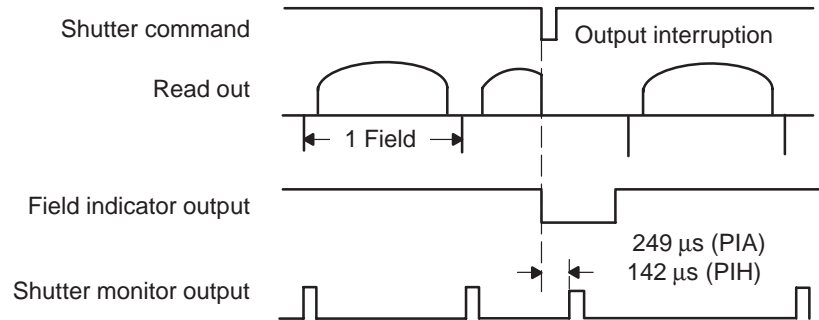

### 4.3 Random Shutter (V Sync Reset)

On the rear panel mode switch SW3, set switch 1 to OFF and switch 2 to ON. Use the shutter speed control switch SW1 to set the shutter speed. Figure 4–3 shows the random shutter speed control timing with V sync reset.

The random shutter operates only when the shutter command has been added, so continuous shutter is the normal operating mode.

Figure 4–3. Random Shutter Control Timing (V Sync Reset)

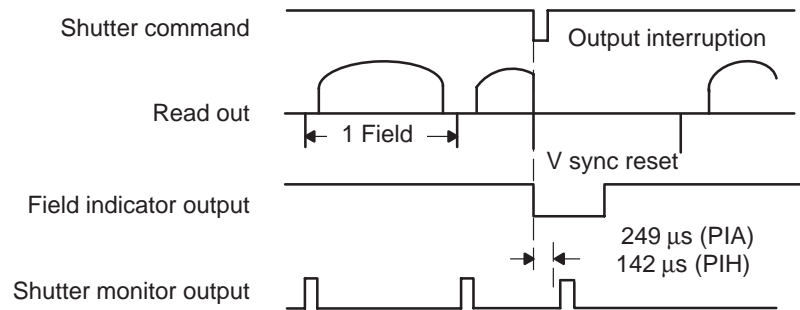

#### 4.4 VI Mode Shutter

On the rear panel mode switch SW3, set switches 1 and 2 to ON. At this point there will be no image output. When an external VI command is input, exposure will occur for the period of the command. This mode is only for non-interlace. The image quality may be lower due to timed exposures; use accordingly. Figure 4–4 shows the VI mode shutter timing.

Figure 4–4. VI Mode Shutter Timing

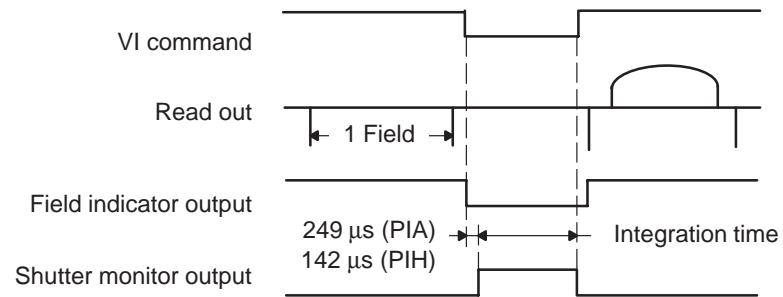

## 4.5 Precautionary Items

Observe the following precautions when operating the electronic shutter.

- ❑ The CCD for this camera uses the frame transfer method. At shutter speeds of 1/500, 1/1000, and 1/1500 second, the exposure period and the transfer period conflict with the readout period. There is black output from the line count, which conforms to the shutter speed; the image output follows. Thus the lower part of the image output cannot be output onto the screen to the degree of the line count of the black output. Figure 4–5 shows what occurs. Table 4–1 lists the line counts for each shutter speed.

Figure 4–5. Exposure and Transfer Period Conflict With Readout Period

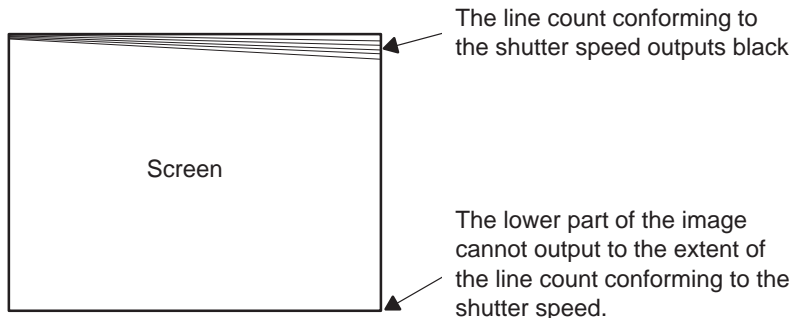

Table 4–1. Line Table Corresponding to Shutter Speeds

Shutter Speed	MC-7890PIA	MC-780PIH
1/500	22	19
1/750	13	11
1/1000	6	3
1/1500	2	–

- ❑ Due to the circumstances noted above, during random shutter, when there is no shutter trigger input, the camera will be in continuous shutter mode. Consequently the bottom part of the image is not shown for shutter speeds of 1/500 through 1/1500 second. Images shot with random shutter have a full image output without the bottom part eliminated. Thus the image appears to flicker because the positions shown on the monitor differ.
- ❑ When a timed exposure is made of over 1/60 second operating in VI mode, impurities on the CCD may become exaggerated. Also, due to the occurrence of dark current, the image may be rough. The image quality of timed exposures is uncertain.
- ❑ Use non-interlace scanning when in random shutter and VI modes.



# Initial Settings



This chapter describes the modes of operation and the initial switch settings.

Topic	Page
5-1 Modes and Initial Switch Settings .....	5-2

## 5.1 Modes and Initial Switch Settings

With this unit it is possible to switch the operating modes to suit the intended use. All mode settings can be set with switches. Table 5–1 summarizes the modes and initial switch settings.

Table 5–1. Modes and Initial Switch Settings

Function	Initial Setting	Setting Switch
<b>Shutter speed switch</b>	—	Rear panel SW1
<b>Gain (sensitivity)</b>	Fixed gain	Rear panel SW2
<input type="checkbox"/> Fixed gain <input type="checkbox"/> Variable gain <input type="checkbox"/> AGC		
<b>Electronic shutter</b>	OFF	Rear panel SW3 – 1, 2
<input type="checkbox"/> OFF <input type="checkbox"/> continuous shutter <input type="checkbox"/> Random shutter (V fixed) <input type="checkbox"/> Random shutter (V reset) <input type="checkbox"/> VI shutter (optional exposure period)	1/60 seconds	
<b>Internal/External Sync</b>	Internal sync	Rear panel SW3 – #, 4
<b>Interlace/Non-Interlace</b>	Interlace	Rear panel SW3 – 5
<b>Sync signal input/output impedance</b>	75Ω	Rear panel SW4
<input type="checkbox"/> 75Ω/150Ω/100kΩ		
<b>Gain variable volume</b>	—	Rear panel VR1
<b>Sync signal input/output</b>	Input	Clock board SW1
<b>Optional input/output shutter</b>	monitor out	Clock board S1
<input type="checkbox"/> Shutter monitor output <input type="checkbox"/> Pixel clock output		
<b>γ switch characteristics</b>	γ = 1	Process board SW1
<input type="checkbox"/> γ = 1/0.45		
<b>Output signal coupling</b>	AC combined output	Process board SW4
<input type="checkbox"/> AC combined out/DC output		
<b>Outline emphasis circuit (PIH only)</b>	OFF	Process board SW2

# Precautions for Use

---

---

---

---

---

Topic	Page
6-1 Precautions for Use .....	6-2
6-2 Maintenance .....	6-3

## 6.1 Precautions for Use

### 6.1.1 Power Source

The camera operates on +12 V. Use a stable ripple- and noise-free power source.

### 6.1.2 Heat Reduction

To keep the temperature inside the camera from rising in some situations (such as when operating the camera inside a tightly sealed case) it may be necessary to use forced air conditioning.

### 6.1.3 Locations for Use and Storage

Do not operate or store the camera in the following locations:

- Locations of extreme heat or cold. The proper temperature for use is 0°C to 40°C.
- Locations with considerable moisture or dust
- Locations in direct contact with rain (the camera is not waterproof or moisture-proof)
- Locations with corrosive gas
- Locations with flammable gas (it is not explosion-proof)
- Locations with severe vibration
- Near radios or television transmitters, which generate strong electrical waves

## 6.2 Maintenance

Use a blower to remove dirt or dust adhering to the CCD glass cover. Wiping the glass forcefully can damage the glass or create static electricity that can damage the CCD.

Use a soft, dry cloth to clean dirt off the exterior. If it is extremely dirty, use a small amount of a neutral detergent on a cloth to remove it, and then wipe with a dry cloth. Do not use alcohol or benzene, as they may discolor the surface and cause peeling.



# Specifications

---

---

---

---

---

This chapter lists the specifications for the cameras.

<b>Topic</b>	<b>Page</b>
7-1 Image System .....	7-2
7-2 Optical Elements and Other Specifications .....	7-3

## 7.1 Image System

Table 7-1 lists the image system specifications for the MC-780PIA; Table 7-2 lists specifications for the MC-780PIH.

*Table 7-1. MC-780PIA Image System Specifications*

<b>Item</b>	<b>Specification</b>
Imager	Frame Transfer Method CCD (TI manufactured CCD TC241-30)
Effective Pixel Count	754 × 484 (horizontal/vertical)
Sensor Screen Area	2/3 inch format (screen size 8.8 mm × 6.6 mm)
Signal System	Based on EIA-170A system

*Table 7-2. MC-780PIH Image System Specifications*

<b>Item</b>	<b>Specification</b>
Imager	Frame Transfer Method CCD (TI manufactured CCD TC245-30)
Effective Pixel Count	754 × 484 (horizontal/vertical)
Sensor Screen Area	1/2 inch format (screen size 6.4 mm × 4.8 mm)
Signal System	Based on EIA-170A system



## 7.2 Optical Elements and Other Specifications

Table 7–3 lists other specifications common to the two cameras.

Table 7–3. Optical Elements and Other Specifications

Item	Specification
Lens Mount	C-mount
Flange back	17.526 mm (can be fine adjusted)
Synchronization System	Internal/External
Sync Input/Output	HD/VD (signal level:TTL level)
Jitter	Within $\pm 60$ nsec
Scanning Method	2:1 interlace/non-interlace
Image Output	1.0 V p-p, Sync negative, 75 $\Omega$ unbalanced
Horizontal Resolution	More than 565 lines
Illumination	0.8 Lux (fixed gain, see Note 1)
Minimum Illumination	0.1 Lux (maximum gain, see Note 1)
S/N Ratio	MC–780PIA: over 53 dB MC–780PIH: over 55 dB
Gain	Auto gain adjust/fixed gain/variable gain
gamma Characteristics	gamma = 1/0.45
White Clip	120IRE $\pm$ 15IRE
Shutter Modes	Continuous shutter/random shutter/VI-mode shutter
Shutter Speeds	1/500, 1/750, 1/1000, 1/1500, 1/2000, 1/3000, 1/4000, 1/8000
Power Source	12 V (range 10.5 V to 15 V)
Power Consumption	Approximately 4.2 W
Operating Temperature	0–40°C
Operating Humidity	20–80% (There must be no dew formation.)
Maintenance Temperature	–20°C to +60°C
Maintenance Humidity	20–95% (There must be no dew formation.)
Oscillation	4.4 G (11–100 Hz)
Exterior Dimensions	44(W) $\times$ 48(H) $\times$ 112(D) mm (includes protruding section)
Weight	215 g
Accessories	Focus Ring Cap (1) User's Manual (1)
AC Adaptor	Japan Local Model (PS-78012J)

- 1) Illumination measured with Davitson Optronics Optoliner.
- 2) These specifications may change without notice due to improvements.



# Exterior Dimensions



This chapter lists exterior dimensions.

<b>Topic</b>	<b>Page</b>
8-1 Exterior Dimensions .....	8-2

## **8.1 Exterior Dimensions**

Figure 8–1 shows the exterior dimensions for the camera. The following notes apply:

- 1) unit:mm
- 2) Since the focus ring is adjustable, this is the middle value (1.2 mm).
- 3) The TI logo for the camera cover is a sticker with one adhesive side.
- 4) The shape and designation may change due to improvements.

Figure 8-1. Exterior Dimensions

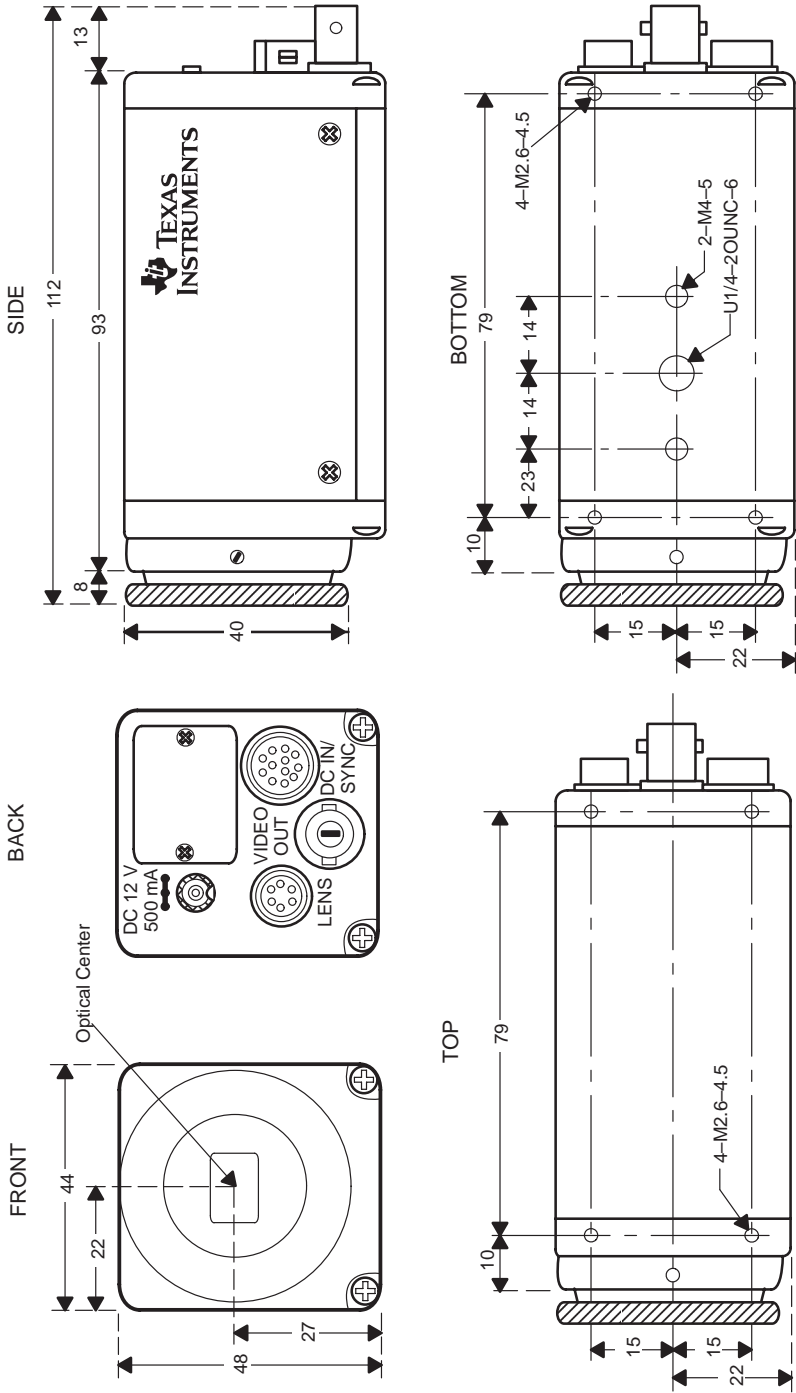



# Other Issues



This chapter discusses cable and connector issues.

Topic	Page
9-1 Connectors .....	9-2

## 9.1 Connectors

We do not sell cable connectors. They can be obtained from appropriate departments of Hirose Electrical Co.

- Main Business Office  
Gotanda I-S Building, 10th Floor  
1-11 Osaki 5-chome, Shinagawa-ku, Tokyo 141  
Telephone: (03)3492-2162  
Fax: (03)3490-9229
  
- Osaka Business Office  
2-22 Tai deramachi, Kita-ku, Osaka 530, Osaka  
Telephone: (06)312-4661  
Fax: (06)312-4335
  
- Cable Part Numbers  
6-pin: HR10A-7P-6P  
12-pin: HR10A-10P-12S



## **IMPORTANT NOTICE**

Texas Instruments and its subsidiaries (TI) reserve the right to make changes to their products or to discontinue any product or service without notice, and advise customers to obtain the latest version of relevant information to verify, before placing orders, that information being relied on is current and complete. All products are sold subject to the terms and conditions of sale supplied at the time of order acknowledgement, including those pertaining to warranty, patent infringement, and limitation of liability.

TI warrants performance of its semiconductor products to the specifications applicable at the time of sale in accordance with TI's standard warranty. Testing and other quality control techniques are utilized to the extent TI deems necessary to support this warranty. Specific testing of all parameters of each device is not necessarily performed, except those mandated by government requirements.

**CERTAIN APPLICATIONS USING SEMICONDUCTOR PRODUCTS MAY INVOLVE POTENTIAL RISKS OF DEATH, PERSONAL INJURY, OR SEVERE PROPERTY OR ENVIRONMENTAL DAMAGE ("CRITICAL APPLICATIONS"). TI SEMICONDUCTOR PRODUCTS ARE NOT DESIGNED, AUTHORIZED, OR WARRANTED TO BE SUITABLE FOR USE IN LIFE-SUPPORT DEVICES OR SYSTEMS OR OTHER CRITICAL APPLICATIONS. INCLUSION OF TI PRODUCTS IN SUCH APPLICATIONS IS UNDERSTOOD TO BE FULLY AT THE CUSTOMER'S RISK.**

In order to minimize risks associated with the customer's applications, adequate design and operating safeguards must be provided by the customer to minimize inherent or procedural hazards.

TI assumes no liability for applications assistance or customer product design. TI does not warrant or represent that any license, either express or implied, is granted under any patent right, copyright, mask work right, or other intellectual property right of TI covering or relating to any combination, machine, or process in which such semiconductor products or services might be or are used. TI's publication of information regarding any third party's products or services does not constitute TI's approval, warranty or endorsement thereof.